



# AQUARIUS ENGINEERS PVT. LTD.

Concrete Pumps, Batching Plants, Boom Pumps



## STATIONARY CONCRETE PUMPS - 700 SERIES

### Salient Features:

- ▶ New futuristic look with latest design
- ▶ Completely redesigned with many operation friendly features
- ▶ Substantial noise reduction
- ▶ Maximum vertical/horizontal pumping distance in this class
- ▶ Most fuel-efficient series
- ▶ Very reliable equipment with long routine maintenance intervals
- ▶ Safe water-cleaning system
- ▶ Compact design and least towing length
- ▶ Very effective reverse pumping
- ▶ Infinitely variable concrete output, from minimum to maximum
- ▶ Centralized greasing points
- ▶ Uninterrupted operations even if electrical system malfunctions
- ▶ Innovative flap straight design with cleaning socket
- ▶ Standardized core pump, reducing spares inventory costs

### Added Features:

- ▶ Higher Capacity jack
- ▶ Foot rest for hopper
- ▶ Gas springs and locks for canopy
- ▶ Shifting cylinder cover for better safety
- ▶ Grill provided for engine cover
- ▶ Built-in toolbox
- ▶ Efficient splash guard design
- ▶ Mudguard on tyre
- ▶ Engine & Pump hour meters
- ▶ Remote control



Worldwide Preferred 'S' Valve Technology

## Technical Specifications:

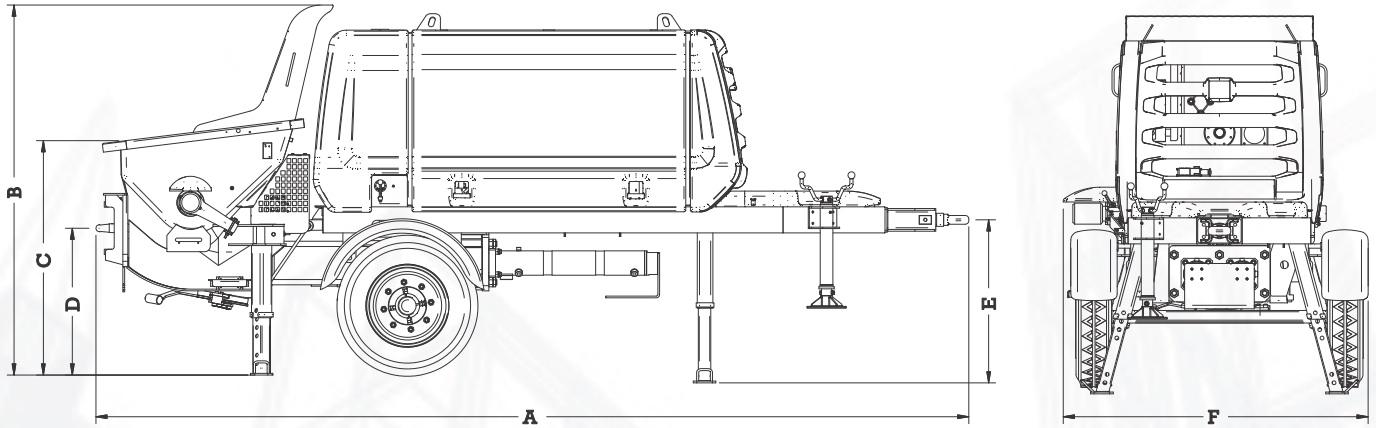

MODEL	A	B	C	D	E	F
700 SERIES	5010	2120	1360	840	940	1740

Model Specifications		Unit	703 D	703 E	704 D
Prime Mover		kW	34.6	37	49
Theoretical Output		m <sup>3</sup> /hr	30	23	35
Del. Cylinder Diameter		mm	200	200	200
Del. Cylinder Stroke		mm	700	700	700
No. of Strokes		per min	22.5	17	26
Hydraulic Transmission		Head Side	1:3.3	1:3.3	1:3.3
Concrete Pressure		bar	65	76	80
Concrete Hopper Capacity		l	500	500	500
Delivery Distance**	Horizontal	m	320	320	350
	Vertical	m	80	80	90

\*\*Distances to be read as either horizontal or vertical. The concrete should be pumpable & follows DIN 1045 standard.



### Largest & Longest 'S' Valve

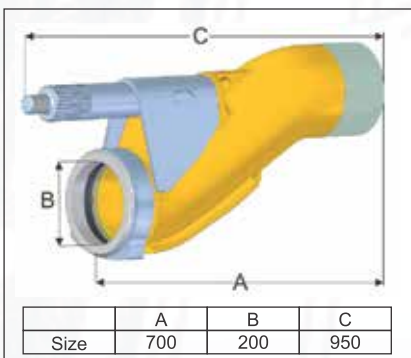

### Variable Output Regulator



### Cylinder Diameter Comparison

#### AQUARIUS

Concrete Pumps



Other

Concrete Pumps



Aquarius Pump Cylinders have larger area than others by 23.5%

Performance of equipment is based on standard working conditions. Design / Specifications can be changed without prior notice.



## AQUARIUS ENGINEERS PVT. LTD.

Concrete Pumps, Batching Plants, Boom Pumps

An ISO 9001 : 2015 Certified Company

'Aquarius House', Sheelavihar Colony, Off Karve Road,

Pune 411 038. INDIA Tel.: +91 20 2544 5227 / 28

E-mail: enquiries@aquariusengineers.biz

Web: www.aquariusengineers.biz

Mfg. by: Putzmeister India Pvt. Ltd.

190, 191, Kundaim Industrial Estate, Kundaim, Goa 403 115. India

Local Contact:

**CONCRETE TECHNOLOGY**

102/1, West Agargaon (7th Floor),  
Sher-E-Banglanagar, Dhaka 1207.

Cell: 01614-099906,07,10

E-mail: info@concretetechnology.com.bd

Web: www.concretetechnology.com.bd